

DESIGN NOTES

Easy-to-Use Differential Amplifiers Simplify Balanced Signal Designs – Design Note 333

Jon Munson

Introduction

The LTC[®]1992 product family provides simple amplification or level translation solutions for amplifying signals that are intrinsically differential or need to be made differential. In addition to the uncommitted configuration of the base LTC1992, fixed gain versions with space-saving on-chip factory-trimmed resistors are available as the LTC1992-1, LTC1992-2, LTC1992-5 and LTC1992-10, where the nominal gain is indicated by the suffix dash number. Figure 1 shows a typical gain-of-ten application where all gain setting components are included in the tiny 8-lead MSOP package.

Easy-to-Use Circuit Topology

The block diagram in Figure 2 shows the general configuration of the differential-in/differential-out CMOS amplifier core, along with an output common mode servo. The values of the on-chip gain resistors depend on the dash suffix of the device as indicated. A convenient on-chip voltage-divider resistor network is also provided to support applications where a source of mid-supply potential (V_{MID}) is needed.

The LTC1992 is easy to use. Any signal difference at the inputs (within the input common mode range) are amplified and presented as a voltage difference at the output

pins with a gain bandwidth product of about 4MHz. The differential gain, A , is set by resistor values:

$$A = R_F/R_G$$

Any input common mode induced errors, primarily caused by small mismatches of resistor values, appear at the output as differential error. The common mode (shared offset) of the output pair is $(V_{OUT+} + V_{OUT-})/2$ and independently governed to track the user-supplied V_{OCM} output common mode control voltage (V_{OCM} may be simply strapped to V_{MID} if desired). The uncommitted LTC1992 (no dash suffix) may be user configured for any desired differential gain by selection of external resistors, or configured specifically for other specialized uses.

LTC and LT are registered trademarks of Linear Technology Corporation.

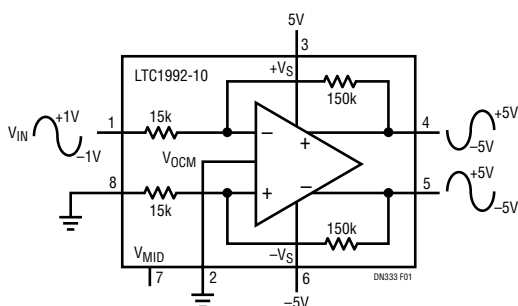

Figure 1. Typical Single-Ended to Differential Conversion

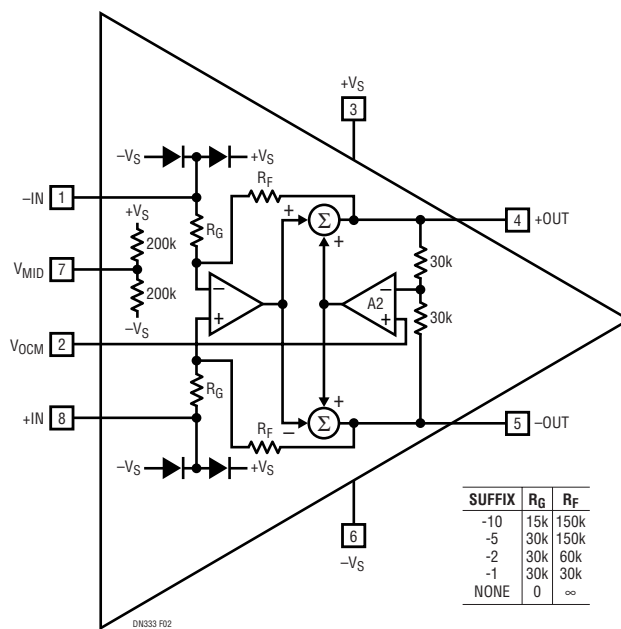

Figure 2. LTC1992 Functional Block Diagram

Common Mode Range Considerations

For a given input common mode voltage (V_{INCM}) and output common mode voltage (V_{OCCM}), the designer must verify that voltage appearing at the internal amplifier inputs (V_{ICM}) is within the specified operating range of $-V_S - 0.1V$ to $+V_S - 1.3V$. With a standard differential amplifier topology having a closed loop gain of A , the following relationship holds:

$$V_{ICM} = (A/(A+1)) \cdot V_{INCM} + (1/(A+1)) \cdot V_{OCCM}$$

For example, assume an LTC1992 (no dash) is powered from 5V, configured for a gain of 2.5 with V_{OCCM} tied to V_{MID} (i.e. 2.5V), and driven from a source with common mode of 0V. From the relation above, V_{ICM} is $(2.5/3.5) \cdot 0 + (1/3.5) \cdot 2.5 = 0.71V$, which is well within the performance range of the device. In this example, the outputs can swing $\pm 2.5V$ around the 2.5V V_{OCCM} level. Therefore, the differential inputs can swing 1V below ground without clipping effects or the need for a minus rail. The dash suffix versions have an additional input limitation due to the possibility of forward biasing the ESD input protection diodes (shown in the Figure 2), which limit the maximum allowable signal swings to 0.3V beyond the supply voltages (while the base LTC1992 also includes the ESD diodes, conduction can only occur outside the usable V_{ICM} range).

Common Mode Input Range Extension

Use of the non-committed LTC1992 provides the possibility of extending input common mode capability well outside the supply range by operating with a gain below

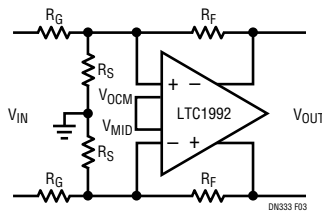

$$\text{GAIN: } A = \frac{R_F}{R_G}$$

$$\text{COMMON MODE SCALING: } m = \frac{R_S}{R_G + R_S}$$

$$V_{ICM} = \frac{A \cdot m \cdot V_{INCM}}{A + m} + \frac{m \cdot V_{OCCM}}{A + m}$$

EXAMPLE: ASSUME $A = 1$, $m = 0.1$, 5V SUPPLY, $V_{OCCM} = 2.5V$
 THUS: $R_F = R_G = 30.1k$, $R_S = 3.32k$, $-3.6V < V_{INCM} < 38V$
 FOR 0.1% RESISTORS, CMRR $\geq 48dB$

Figure 3. Extending Input Common Mode Range

Data Sheet Download

<http://www.linear.com/go/dnLTC1992>

unity and/or introducing common mode shunt resistors (see R_S in Figure 3). The drawback to the shunt resistor method is that component tolerances of R_G and R_S become magnified by the common mode improvement of the circuit (approximately), leading to reduced CMRR performance for a given resistor tolerance. For low gain operation, common mode extension of 10 \times is realizable with the use of high accuracy resistor networks.

Versatile Functional Block

The LTC1992 family is especially useful for making conversions to or from differential signaling. Analog-to-digital converters (ADCs) are often optimized for differential inputs with a specific common mode input voltage. Use of an LTC1992 amplifier simplifies the ADC interface by using the V_{OCCM} control feature to establish the requisite offset. In many cases, the mid-scale potential is provided by the ADC and can be tied directly to the V_{OCCM} input. In addition, the source signal input may then be differential or single ended (by grounding the unused input) or have inverted polarity.

Since it is not necessary to connect to both outputs, one can treat the part as single ended which provides the useful feature that the V_{OCCM} input represents a third algebraic input term (see Figure 4). This capability is useful in performing analog addition or simple translation functions.

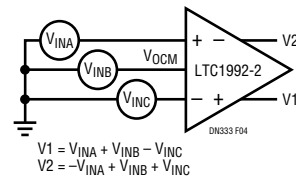

$$V1 = V_{INA} + V_{INB} - V_{INC}$$

$$V2 = -V_{INA} + V_{INB} + V_{INC}$$

Figure 4. Single Ended Adder/Subtractor

Conclusion

The LTC1992 family of differential amplifiers offers easy-to-use building blocks that provide simple, minimum component-count solutions to balanced-signal designs. These parts are useful in a wide range of applications, including simple methods of transforming signals to/from differential form to providing component-free gain or DC offset functions.

For applications help,
 call (408) 432-1900, Ext. 2156